

Plan View
(Top Not Shown)

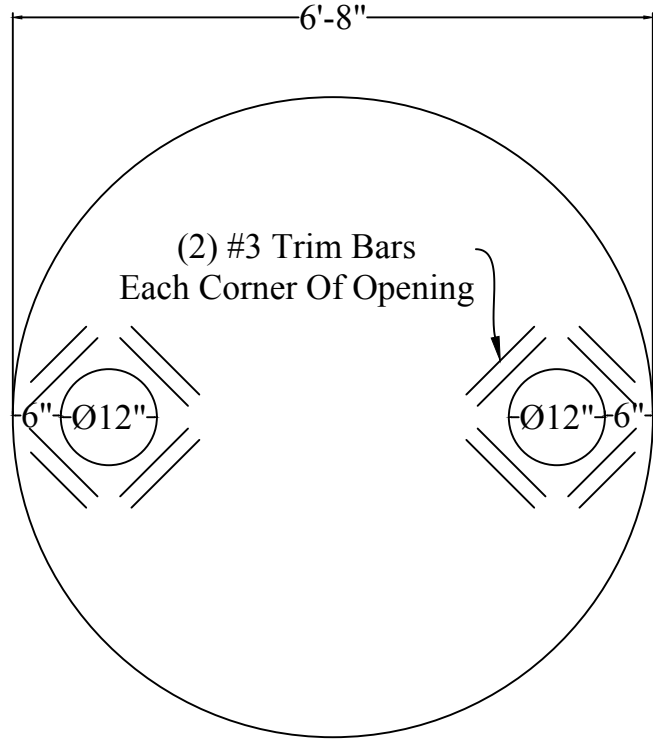

Top Slab Plan View

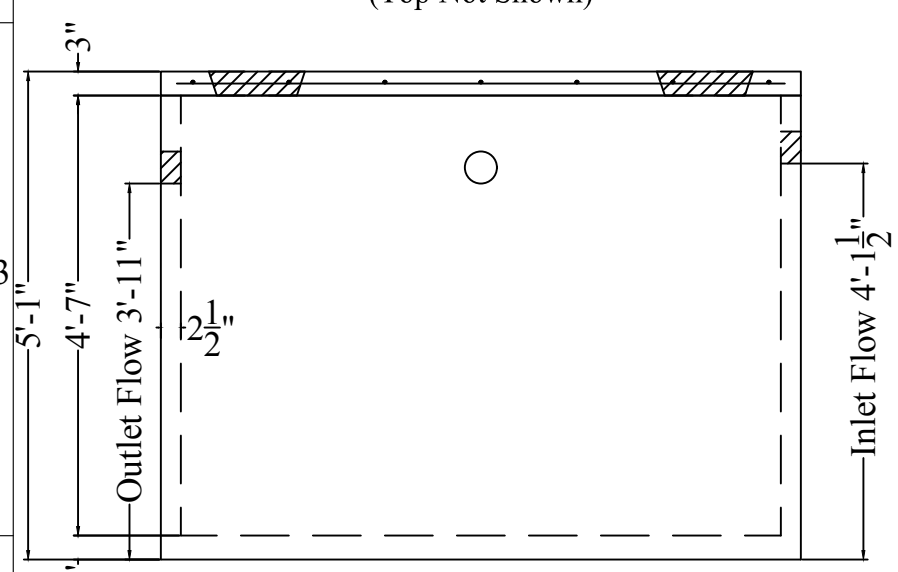

Elevation

- Notes:
1. Concrete: Design Strength 5,000 PSI @ 28 Days
 2. Reinforcement: ASTM A-615, Grade 60 or ASTM A-1064 Welded Wire Fabric
 3. Product Tolerances are in Accordance With ASTM C913, Section 7

Individual Weights	
Base	Top Slab
4375	1050

 <p>Turner Co. P.O. Box 885 Rhome, TX 76078</p>	DRAWN BY: TSH	JOB NO:	DATE: 07/27/22	WEIGHT: 5425#	Revision Number R0	Sheet 1 of 1
	PRODUCT 750 Gallon Septic Tank			JOB NAME		